

# burks®

## INSTALLATION AND OPERATION MANUAL

### Condensate Return Systems - Series: GV

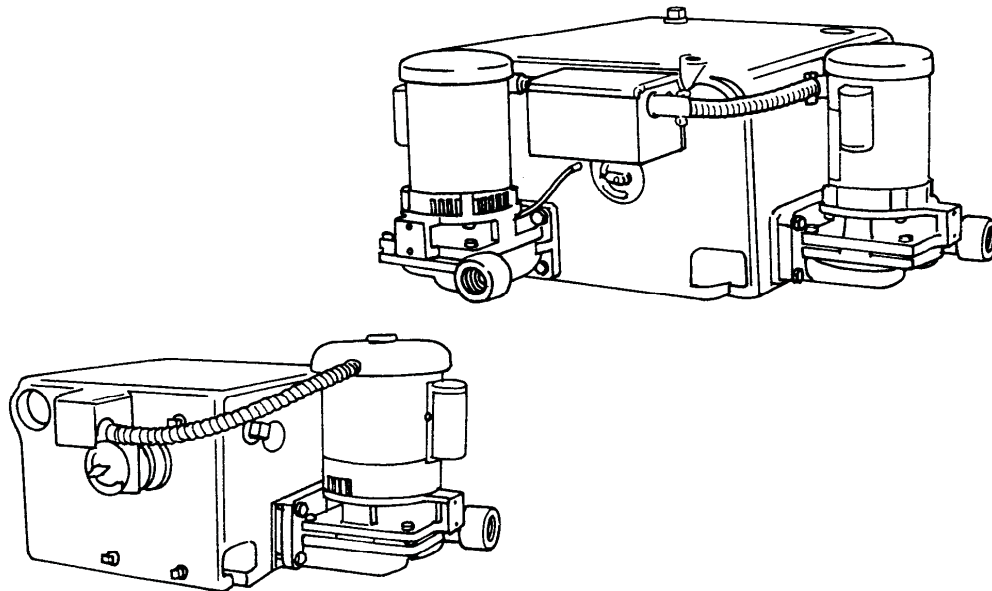

**WARNING!**

The receiver tank is **NOT** a pressure vessel. It **MUST** be vented to atmosphere to prevent pressure buildup. Any internal pressure other than that due to the weight of fluid in the tank IS UNSAFE - Warranty is void if receiver tank is pressurized.

**IMPORTANT!**

*Read all instructions in this manual before operating pump.  
DO NOT work on pump until you are sure pump and associated piping are totally depressurized, pump and motor have cooled down, and electricity to the motor has been shut off and locked out.  
As a result of Crane Pumps & Systems, Inc., constant product improvement program, product changes may occur. As such Crane Pumps & Systems reserves the right to change product without prior written notification.*

**CRANE**<sup>®</sup>

A Crane Co. Company

### PUMPS & SYSTEMS

420 Third Street  
Piqua, Ohio 45356  
Phone: (937) 778-8947  
Fax: (937) 773-7157  
[www.cranepumps.com](http://www.cranepumps.com)

83 West Drive, Bramton  
Ontario, Canada L6T 2J6  
Phone: (905) 457-6223  
Fax: (905) 457-2650

# SAFETY FIRST!

Please Read This Before Installing Or Operating Pump. This information is provided for **SAFETY** and to **PREVENT EQUIPMENT PROBLEMS**. To help recognize this information, observe the following symbols:



**IMPORTANT!** Warns about hazards that can result in personal injury or indicates factors concerned with assembly, installation, operation, or maintenance which could result in damage to the machine or equipment if ignored.

**CAUTION!** Warns about hazards that **can or will cause minor** personal injury or property damage if ignored. Used with symbols below.

**WARNING!** Warns about hazards that can or will cause serious personal injury, death, or major property damage if ignored. Used with symbols below.



Hazardous fluids can cause fire or explosions, burns or death could result.



Extremely hot - Severe burns can occur on contact.



Biohazard can cause serious personal injury.



Hazardous fluids can Hazardous pressure, eruptions or explosions could cause personal injury or property damage.



Rotating machinery Amputation or severe laceration can result.



Hazardous voltage can shock, burn or cause death.

Only qualified personnel should install, operate and repair pump. Any wiring of pumps should be performed by a qualified electrician.

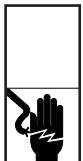

**WARNING!** To reduce risk of electrical shock, pumps and control panels must be properly grounded in accordance with the National Electric Code (NEC) or the Canadian Electrical Code (CEC) and all applicable state, province, local codes and ordinances. Improper grounding voids warranty.



**WARNING!** To reduce risk of electrical shock, always disconnect the pump from the power source before handling or servicing. Lock out power and tag.



**WARNING!** Operation against a closed discharge valve will cause premature bearing and seal failure on any pump, and on end suction and self priming pump the heat build may cause the generation of steam with resulting dangerous pressures. It is recommended that a high case temperature switch or pressure relief valve be installed on the pump body.



**CAUTION!** Pumps build up heat and pressure during operation-allow time for pumps to cool before handling or servicing.



**WARNING!** This pump is designed to handle materials which could cause illness or disease through direct exposure. Wear adequate protective clothing when working on the pump or piping.



**WARNING!** Do not pump hazardous materials (flammable, caustic, etc.) unless the pump is specifically designed and designated to handle them.



**WARNING!** Do not wear loose clothing that may become entangled in moving parts.



**WARNING!** Keep clear of suction and discharge openings. **DO NOT** insert fingers in pump with power connected.



Make sure lifting handles are securely fastened each time before lifting. **DO NOT** operate pump without safety devices in place. Always replace safety devices that have been removed during service or repair. Secure the pump in its operating position so it can not tip over, fall or slide.



**WARNING!** To reduce risk of electrical shock, all wiring and junction connections should be made per the NEC or CEC and applicable state or province and local codes. Requirements may vary depending on usage and location.



**WARNING!** Products returned must be cleaned, sanitized, or decontaminated as necessary prior to shipment, to insure that employees will not be exposed to health hazards in handling said material. All Applicable Laws And Regulations Shall Apply.



Crane Pumps & Systems, Inc. is not responsible for losses, injury, or death resulting from a failure to observe these safety precautions, misuse or abuse of pumps or equipment.

Bronze/brass and bronze/brass fitted pumps may contain lead levels higher than considered safe for potable water systems. Lead is known to cause cancer and birth defects or other reproductive harm. Various government agencies have determined that leaded copper alloys should not be used in potable water applications. For non-leaded copper alloy materials of construction, please contact factory.

## GENERAL INFORMATION

### To the Purchaser:

**Congratulations!** You are the owner of one of the finest pumps on the market today. Burks® Pumps are products engineered and manufactured of high quality components. Over eighty years of pump building experience along with a continuing quality assurance program combine to produce a pump which will stand up to the toughest pumping projects.

This manual will provide helpful information concerning installation, maintenance, and proper service guidelines.

### Receiving:

Upon receiving the pump, it should be inspected for damage or shortages. If damage has occurred, file a claim immediately with the company that delivered the pump. If the manual is removed from the crating, do not lose or misplace.

### Storage:

**Short Term** - Burks Pumps are manufactured for efficient performance following long inoperative periods in storage. For best results, pumps can be retained in storage, as factory assembled, in a dry atmosphere with constant temperatures for up to six (6) months.

**Long Term** - Any length of time exceeding six (6) months, but not more than twenty four (24) months. The units should be stored in a temperature controlled area, a roofed over walled enclosure that provides protection from the elements (rain, snow, wind blown dust, etc.), and whose temperature can be maintained between +40 deg. F and +120 deg. F.

If extended high humidity is expected to be a problem, all exposed parts should be inspected before storage and all surfaces that have the paint scratched, damaged, or worn should be recoated with a water base, air dry enamel paint. All surfaces should then be sprayed with a rust-inhibiting oil.

## INSTALLATION

1. Wet return line should be connected to the tapping in the receiver tank.
2. Strainer/Dirt Trap should be installed in the return line immediately before the receiver tank.
3. Check Valve should be installed between the boiler and the pump.
4. Vent to atmosphere from tapped opening in the top of the tank using 1" line or larger. Do not use valves or traps in the vent line. A tee in the vent line, connected to a drain, will direct overflow water to drain in case of a pump failure.



**WARNING - The receiver tank is NOT a pressure vessel. It MUST be vented to atmosphere to prevent pressure build-up. Any internal pressure other than that due to the weight of fluid in the tank IS UNSAFE - Warranty is void if receiver tank is pressurized.**

5. Float Switch or Mechanical Alternator should be wired by competent electrician to insure proper performance of the motor. Before wiring, make certain the voltage and cycles of the supply circuit are the same as on the motor nameplate. Refer to wiring diagram on motor nameplate and on switch tag. Controls are factory set for specific float travel. Float travel may be adjusted for close control of receiver water level. See attached tag for detailed instructions.

## OPERATING

1. Open all valves in return line and discharge line to boiler.
2. Apply electrical power to system.  
When water level in receiver tank reaches proper level, float switch or alternator will actuate pump motor to return condensate to boiler.

## MAINTENANCE LUBRICATION

No lubrication is required for the liquid end of the pump. Motors are equipped with ball bearings which are grease-packed and sealed at the factory. No additional lubrication is required.

Steam Traps should be carefully checked and kept clean. Live steam escaping from receiver tank vent indicates faulty operation of trap.

Strainer/Dirt Trap should be cleaned twice yearly, or oftener if required. Remove cap and screen and flush out trap body.

Tank Drain - Tank should be drained at the end of each heating season by removing drain plug located below return line connection. Do not expose unit to freezing temperatures when it contains water.



**CAUTION - Boiler Compound should NOT be introduced into the system through the receiver tank, but added on the discharge side of the pump by means of a commercial injector designed for that purpose. This will prevent wear or clogging caused by certain types of boiler compounds which do not completely dissolve.**

If it should be necessary to contact your BURKS dealer, distributor, or the factory regarding your Series GV Condensate Return System, always give the Catalog Number and Serial Number found on the pump nameplate.

**BARNES®**



**burks®**

**WEINMAN®**

**DEMING®**

**PROSSER®**

## *Limited 24 Month Warranty*

Crane Pumps & Systems warrants that products of our manufacture will be free of defects in material and workmanship under normal use and service for twenty-four (24) months after manufacture date, when installed and maintained in accordance with our instructions. This warranty gives you specific legal rights, and there may also be other rights which vary from state to state. In the event the product is covered by the Federal Consumer Product Warranties Law (1) the duration of any implied warranties associated with the product by virtue of said law is limited to the same duration as stated herein, (2) this warranty is a LIMITED WARRANTY, and (3) no claims of any nature whatsoever shall be made against us, until the ultimate consumer, his successor, or assigns, notifies us in writing of the defect, and delivers the product and/or defective part(s) freight prepaid to our factory or nearest authorized service station. Some states do not allow limitations on how long an implied warranty lasts, so the above limitation may not apply. **THE SOLE AND EXCLUSIVE REMEDY FOR BREACH OF ANY AND ALL WARRANTIES WITH RESPECT TO ANY PRODUCT SHALL BE TO REPLACE OR REPAIR AT OUR ELECTION, F.O.B. POINT OF MANUFACTURE OR AUTHORIZED REPAIR STATION, SUCH PRODUCTS AND/OR PARTS AS PROVEN DEFECTIVE. THERE SHALL BE NO FURTHER LIABILITY, WHETHER BASED ON WARRANTY, NEGLIGENCE OR OTHERWISE.** Unless expressly stated otherwise, guarantees in the nature of performance specifications furnished in addition to the foregoing material and workmanship warranties on a product manufactured by us, if any, are subject to laboratory tests corrected for field performance. Any additional guarantees, in the nature of performance specifications must be in writing and such writing must be signed by our authorized representative. Due to inaccuracies in field testing if a conflict arises between the results of field testing conducted by or for user, and laboratory tests corrected for field performance, the latter shall control. **RECOMMENDATIONS FOR SPECIAL APPLICATIONS OR THOSE RESULTING FROM SYSTEMS ANALYSES AND EVALUATIONS WE CONDUCT WILL BE BASED ON OUR BEST AVAILABLE EXPERIENCE AND PUBLISHED INDUSTRY INFORMATION. SUCH RECOMMENDATIONS DO NOT CONSTITUTE A WARRANTY OF SATISFACTORY PERFORMANCE AND NO SUCH WARRANTY IS GIVEN.**

This warranty shall not apply when damage is caused by (a) improper installation, (b) improper voltage (c) lightning (d) excessive sand or other abrasive material (e) scale or corrosion build-up due to excessive chemical content. Any modification of the original equipment will also void the warranty. We will not be responsible for loss, damage or labor cost due to interruption of service caused by defective parts. Neither will we accept charges incurred by others without our prior written approval.

This warranty is void if our inspection reveals the product was used in a manner inconsistent with normal industry practice and/or our specific recommendations. The purchaser is responsible for communication of all necessary information regarding the application and use of the product. **UNDER NO CIRCUMSTANCES WILL WE BE RESPONSIBLE FOR ANY OTHER DIRECT OR CONSEQUENTIAL DAMAGES, INCLUDING BUT NOT LIMITED TO TRAVEL EXPENSES, RENTED EQUIPMENT, OUTSIDE CONTRACTOR FEES, UNAUTHORIZED REPAIR SHOP EXPENSES, LOST PROFITS, LOST INCOME, LABOR CHARGES, DELAYS IN PRODUCTION, IDLE PRODUCTION, WHICH DAMAGES ARE CAUSED BY ANY DEFECTS IN MATERIAL AND/OR WORKMANSHIP AND/OR DAMAGE OR DELAYS IN SHIPMENT. THIS WARRANTY IS EXPRESSLY IN LIEU OF ANY OTHER EXPRESS OR IMPLIED WARRANTY, INCLUDING ANY WARRANTY OF MERCHANTABILITY OR FITNESS FOR A PARTICULAR PURPOSE.**

No rights extended under this warranty shall be assigned to any other person, whether by operation of law or otherwise, without our prior written approval.

**CRANE®**

**PUMPS & SYSTEMS**

A Crane Co. Company

420 Third Street  
Piqua, Ohio 45356  
Phone: (937) 778-8947  
Fax: (937) 773-7157  
www.cranepumps.com

83 West Drive, Brampton  
Ontario, Canada L6T 2J6  
Phone: (905) 457-6223  
Fax: (905) 457-2650

**IMPORTANT!  
WARRANTY REGISTRATION**

Your product is covered by the enclosed Warranty.  
To complete the Warranty Registration Form go to:

<http://www.cranepumps.com/ProductRegistration/>

If you have a claim under the provision of the warranty, contact your local  
Crane Pumps & Systems, Inc. Distributor.

**RETURNED GOODS**

**RETURN OF MERCHANDISE REQUIRES A "RETURNED GOODS AUTHORIZATION".  
CONTACT YOUR LOCAL CRANE PUMPS & SYSTEMS, INC. DISTRIBUTOR.**



**Products Returned Must Be Cleaned, Sanitized,  
Or Decontaminated As Necessary Prior To Shipment,  
To Insure That Employees Will Not Be Exposed To Health  
Hazards In Handling Said Material. All Applicable Laws  
And Regulations Shall Apply.**

